

## Wedge grips 20kN and 50kN

Multi purpose, self-tightening grips.

Suitable for metal or plastic specimens (with medium strength) etc.

Easy to use: The grips feature a lever arm for quick loading and releasing of the samples.

The wedge-shaped design of the jaws causes the clamping force to increase, as tension is applied during the test.



Item No.	TH243-20	TH243-50
Tensile force	20 kN	50 kN
Temperature range	0°C - +130°C (TH243-20) -70°C - +280°C (TH243-20-Ni) -70°C - +280°C (TH243-20+TK Option)	0°C - +130°C (TH243-50) -70°C - +280°C (TH243-50-Ni) -70°C - +280°C (TH243-50+TK Option)
Body	Steel, phosphate coated (TH243-20) Steel, nickel plated (TH243-20-Ni)	Steel, phosphate coated (TH243-50) Steel, nickel plated (TH243-50-Ni)
Weight	3.8 kg each grip (without jaws)	6.75 kg each grip (without jaws)



TH243-20-Ni

Wedge jaws for TH243 grips: scope of delivery 1 set = 4 jaws

Item No.	Surface	Clamping surface H x W	Opening	Weight per pair
TH243-BP	Pyramid (serrated) jaws	50 x 35mm	0 – 13mm	0.48 kg
TH243-BP16	Pyramid (serrated) jaws	50 x 35mm	4 – 16mm	0.41 kg
TH243-BV	V-jaws	Clamping height 50mm	3 – 13mm Ø	0.46 kg
TH243-BV16	V-jaws	Clamping height 50mm	4 – 16mm Ø	0.41 kg

Jaws with other dimensions and surface coatings on request

	<p>TH243-BP Pyramid jaws</p> <ul style="list-style-type: none"> <li>• Hardened steel 58 HRC</li> <li>• Pyramids 1.2 x 45°</li> </ul>		<p>TH243-BV -V-jaws</p> <ul style="list-style-type: none"> <li>• For all kinds of round samples</li> <li>• Hardened steel 58 HRC</li> <li>• Tooth pitch 1.2 mm</li> </ul>
---	--	---	---



TH243-20+TK Option  
(for TH243-20 and TH243-50)

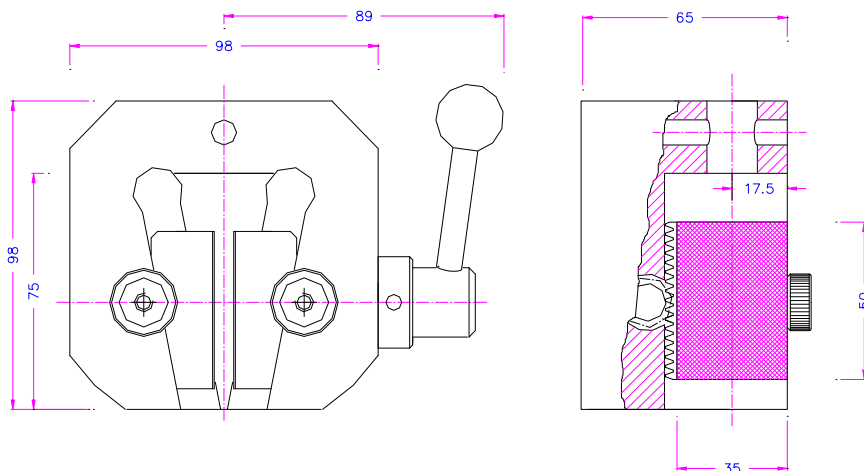

TH243-20

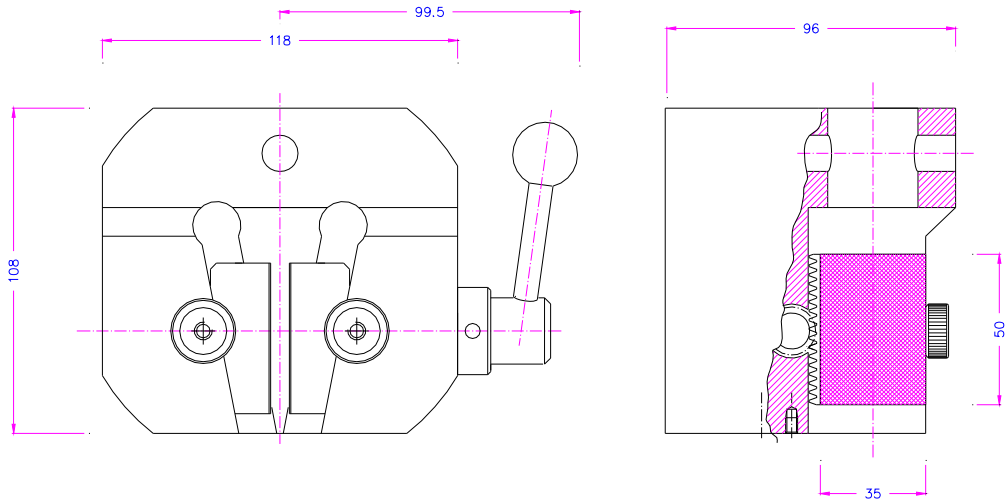

TH243-50

Examples of other versions and custom built solutions



**Ordering information**

TH243 grips are supplied as a pair, but can also be ordered separately (0.5 pair). Grips and jaws need to be ordered separately.