

FORMEN FÜR PROBENVORBEREITUNG

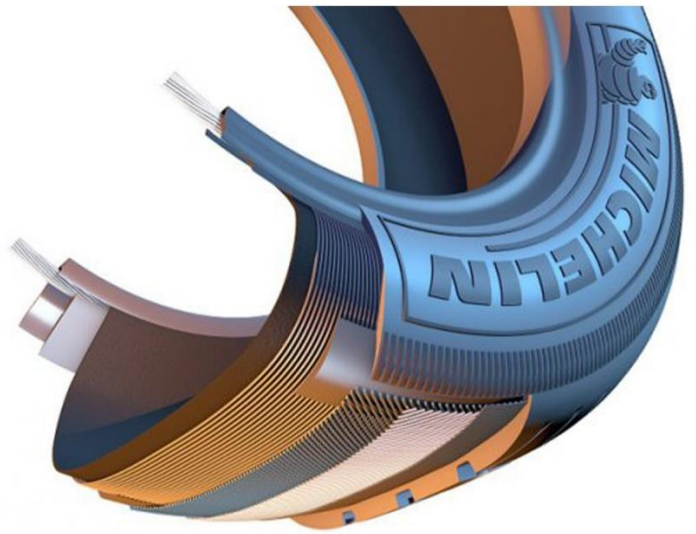

FORMEN FÜR PROBENVORBEREITUNG

Prüfnorm:	Artikel-Nr.:
ISO62	THS1390-MLD-61x61x1-ISO62
ISO178	THS1390-MLD-GT-100x200 + Ex
ISO527-2 Typ 1A	THS1390-MLD-10x80-ISO527-2-Type1A-ISO604-TypeB
ISO604 Typ B	THS1390-MLD-GT-100x200 + Ex
ASTM-D395	THS1390-MLD-13x6-ASTM-D395
ASTM-D2229	THS1390-MLD-200x12.5-BISFA-E12-ASTM-D2229
ASTM-D3039	THS1390-MLD-175x25-ASTM-D3039 THS1390-MLD-250x15-ASTM-D3039
ASTM-D3182	THS1390-MLD-150x150x2.5-ASTM-D3182
BISFA-E12	THS1390-MLD-200x12.5-BISFA-E12-ASTM-D2229
GOST26366-Fig.4	THS1390-MLD-212x12.5-GOST26366-Fig.4
GOST26366-Fig.2	THS1390-MLD-2x25-GOST26366-Fig.2 + THS1390-MLD-100g+200g
UL94	THS1390-MLD-GT-100x200 + Ex

Legende:

THS1390-MLD-A-B-C-D

MLD = Mold A, B, C = Abmessungen des Prüflings D = Prüfnorm

Inhalt

THS1390-MLD-10x80-ISO527-2-Type1A-ISO604-TypeB	2
THS1390-MLD-61x61x1-ISO62.....	3
THS1390-MLD-GT-100x200 + Ex	4
THS1390-MLD-150x150x2.5-ASTM-D3182.....	5
THS1390-MLD-200x12.5-BISFA-E12-ASTM-D2229	6
THS1390-MLD-13x6-ASTM-D395.....	7
THS1390-MLD-175x25-ASTM-D3039.....	8
THS1390-MLD-250x15-ASTM-D3039.....	8
THS1390-MLD-212x12.5-GOST26366-Fig.4	9
THS1390-MLD-2x25-GOST26366-Fig.2 + THS1390-MLD-100g+200g	10

THS1390-MLD-10x80-ISO527-2-Type1A-ISO604-TypeB

ISO 527-2
Zugversuch an Kunststoffen

ISO 604
Druckversuch an Kunststoffen

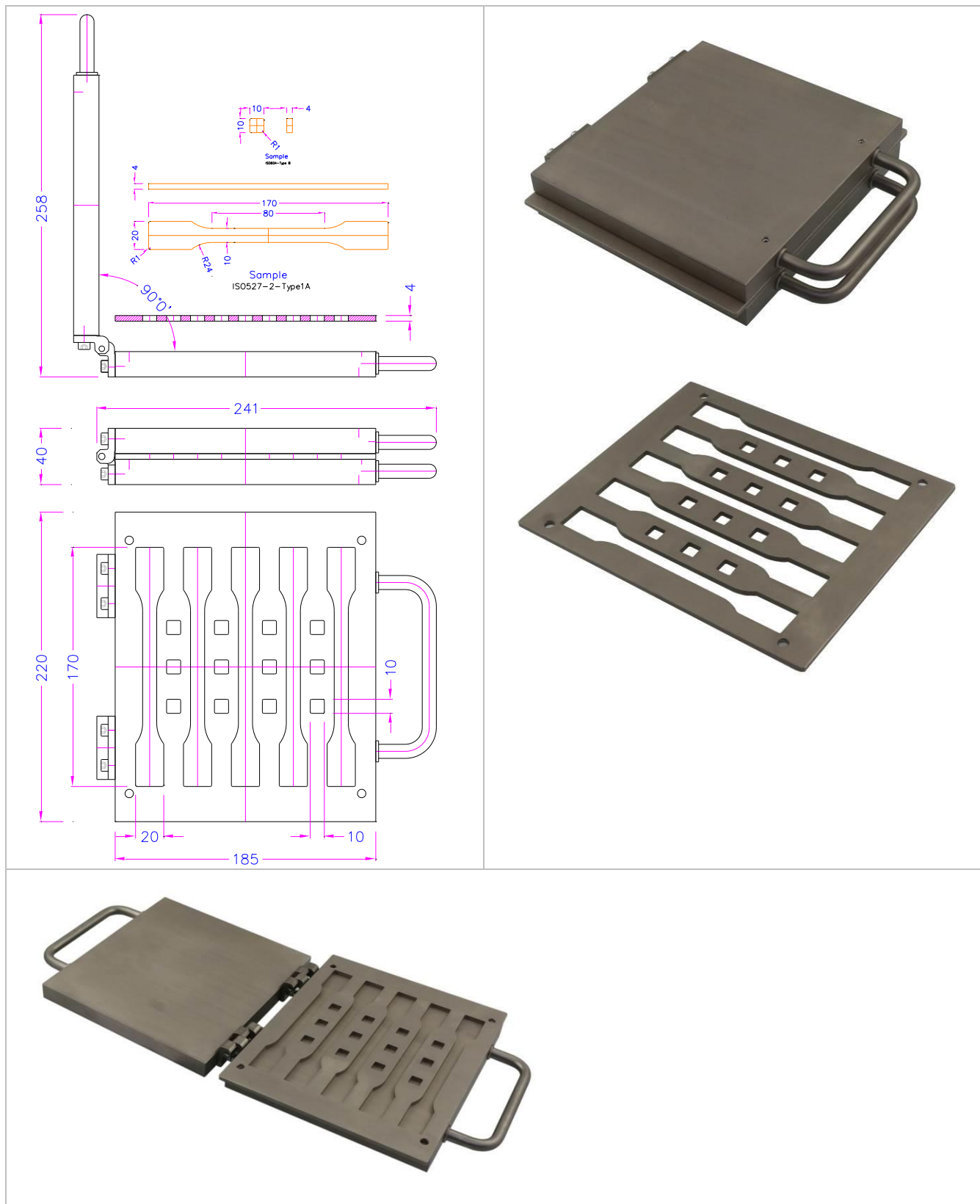

THS1390-MLD-61x61x1-ISO62

Kunststoffe - Bestimmung der Wasseraufnahme

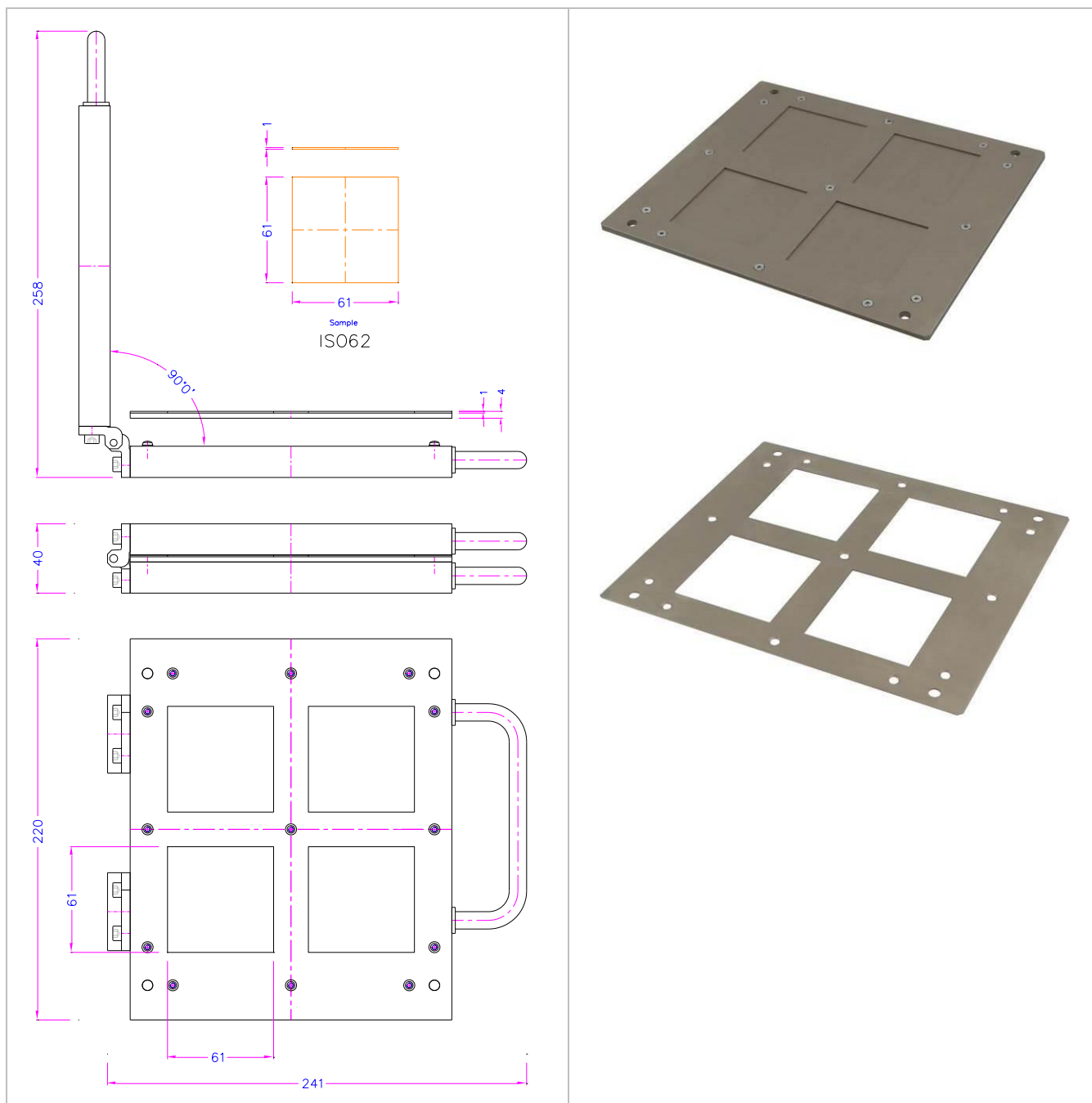

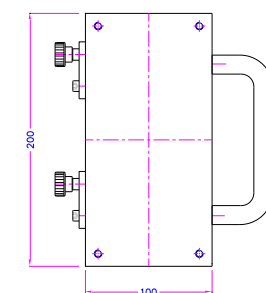
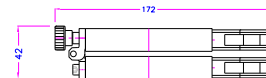
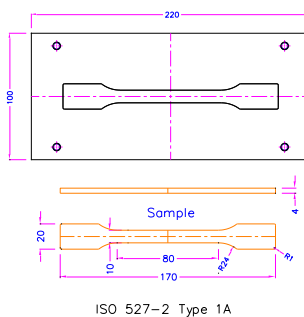
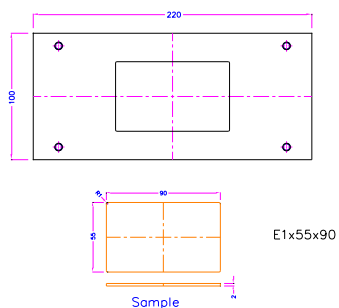
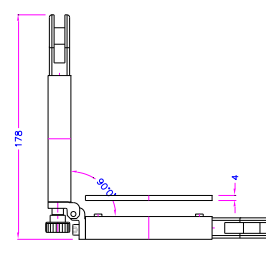
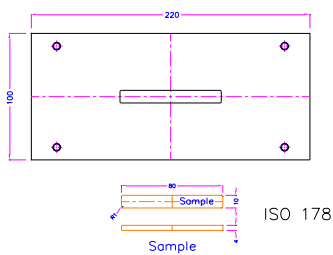
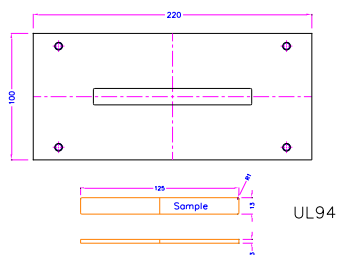

THS1390-MLD-GT-100x200 + Ex

Grundträger für Einsätze:
THS1390-MLD-GT-100x200

Einsätze:

- THS1390-MLD-E1x10x80-ISO527-2
- THS1390-MLD-E1x10x80-ISO178
- THS1390-MLD-E1x13x125-UL94
- THS1390-MLD-E1x55x90

THS1390-MLD-150x150x2.5-ASTM-D3182

Prüfung von Kautschuk; Geräte und Verfahren zur Herstellung von Standardtestmischungen und Elastomer-Standardplatten

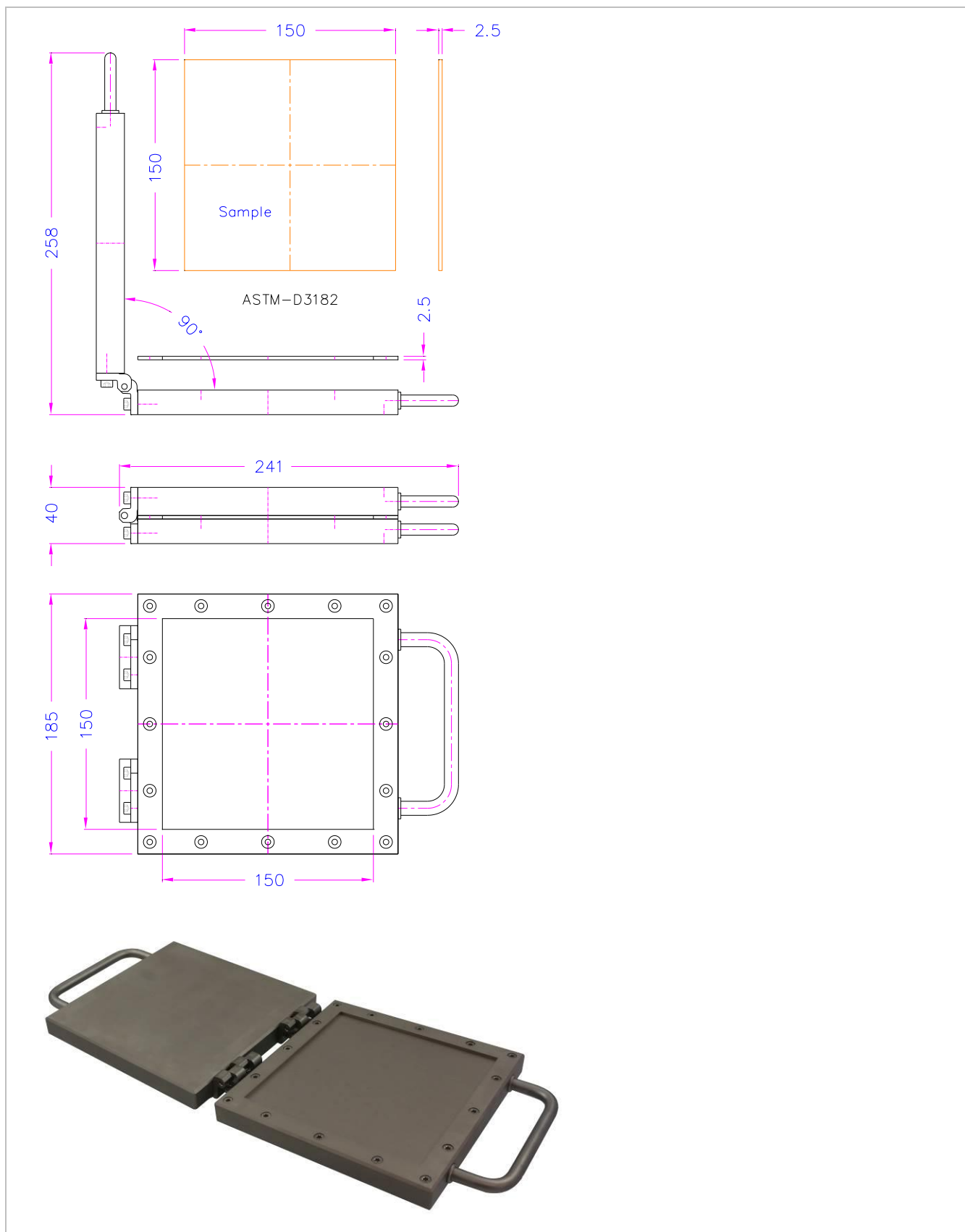

THS1390-MLD-200x12.5-BISFA-E12-ASTM-D2229

Haftung zwischen Stahlreifenkorden und Gummi

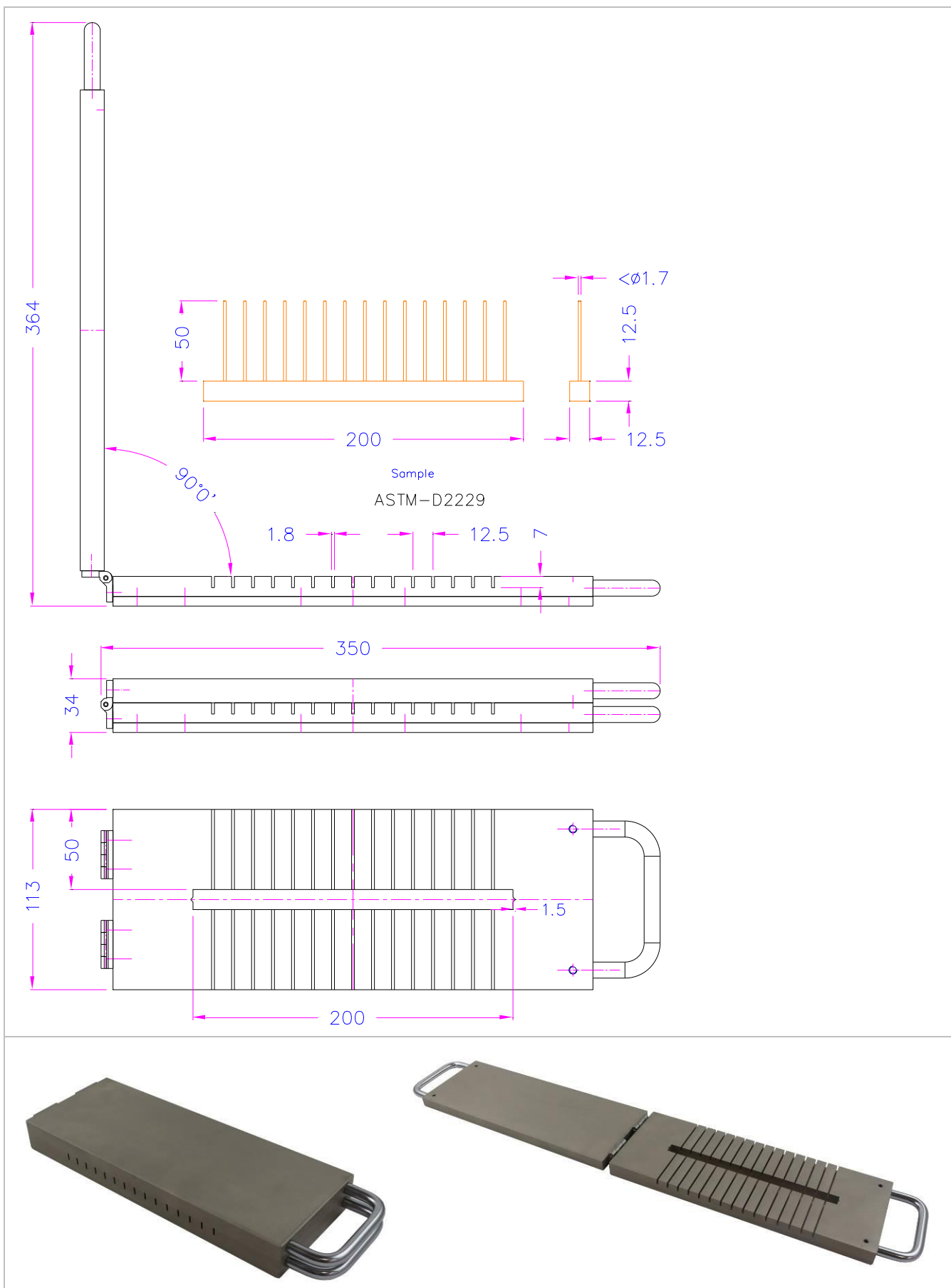

THS1390-MLD-13x6-ASTM-D395

Prüfung von Kautschuk; Bestimmung des Druckverformungsrestes

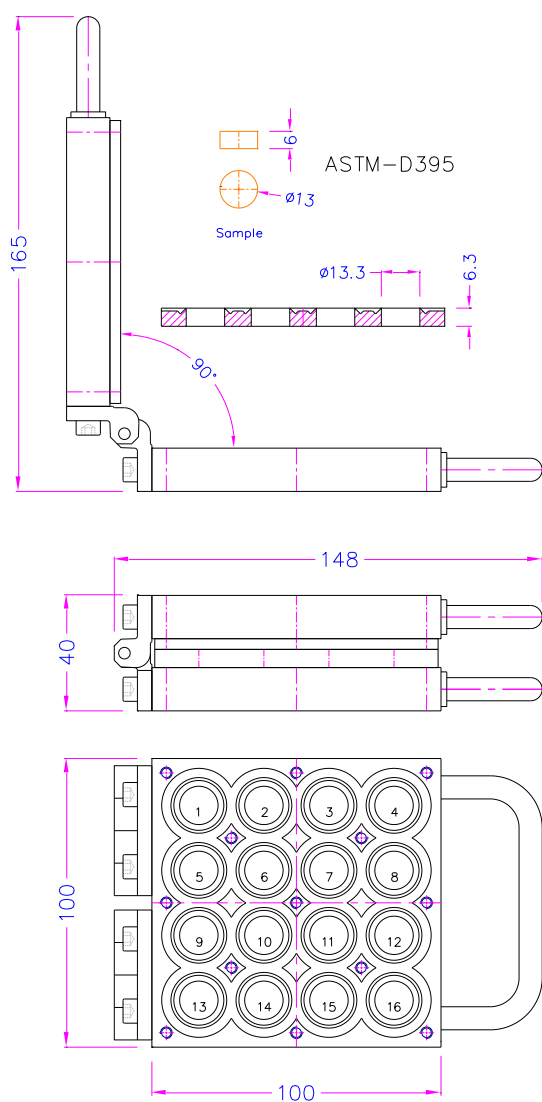

THS1390-MLD-175x25-ASTM-D3039

THS1390-MLD-250x15-ASTM-D3039

Zugversuch an Polymer-Matrix-Verbundwerkstoffen

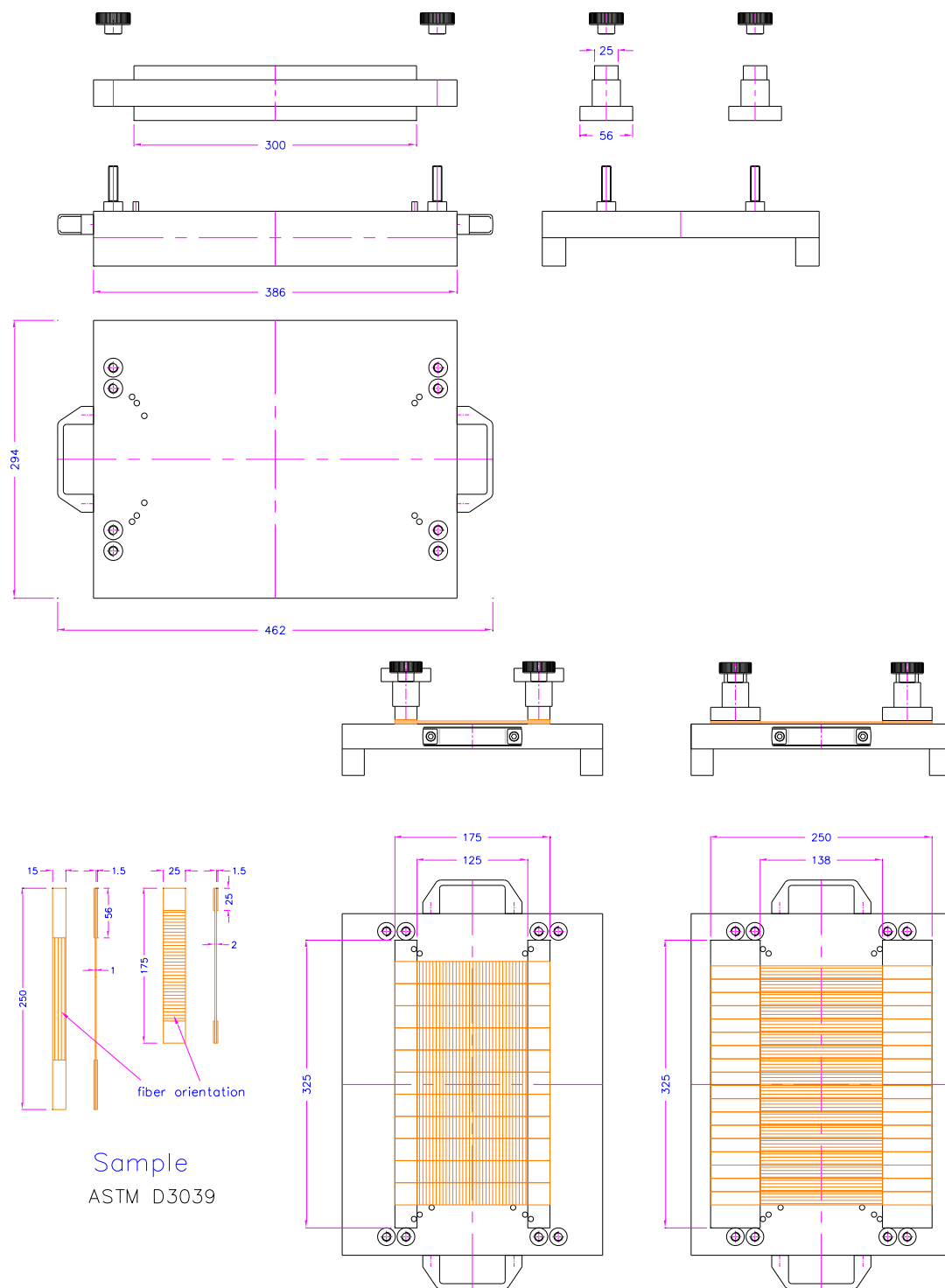

THS1390-MLD-212x12.5-GOST26366-Fig.4

Haftung zwischen messingbeschichteten Stahlreifenkorden und Gummi

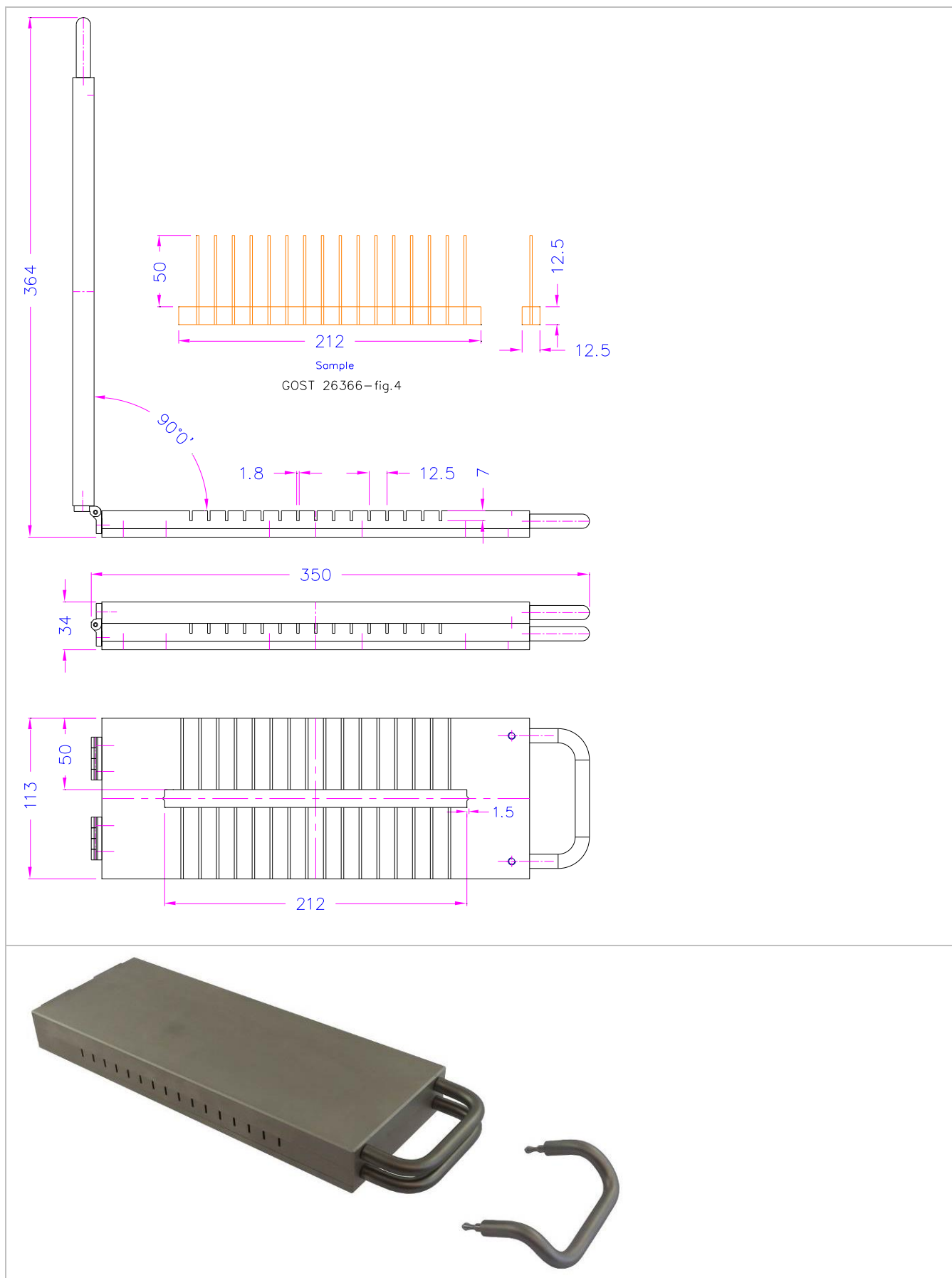

THS1390-MLD-2x25-GOST26366-Fig.2 + THS1390-MLD-100g+200g
 Haftung zwischen messingbeschichteten Stahlreifenkorden und Gummi

